

### **SERVICE**

If the instrument fails to operate, check battery, test leads, etc and replace as necessary. If the instrument still malfunctions, please call the phone number listed below:

Service Division  
AMPROBE INSTRUMENT  
Miami, Florida 33150  
Tel: 800-327-5060

outside the U.S.A. the local Amprobe representative will assist you.

 **AMPROBE®**  
DIVISION OF CORE INDUSTRIES INC.  
Miami, Florida 33150  
Tel: 800-327-5060  
Visit our Web-site [HTTP://www.AMPROBE.COM](http://www.AMPROBE.COM)

Manual P/N: 978760  
8/97

**USER MANUAL**

**AUNIQUE AC / DC TRUE RMS  
CLAMP-ON MULTIMETER**

**MODEL: ACDC-620T**



CE



C

LISTED

 **AMPROBE®**  
Miramar, Florida 33025  
Tel: 800-327-5060

### LIMITED WARRANTY

Congratulations! You are now the owner of an AMPROBE® instrument. It has been quality crafted according to quality standards and contains quality components and workmanship. This instrument has been inspected for proper operation of all its functions. It has been tested by qualified factory technicians according to the long-established standards of AMPROBE®.

Your AMPROBE® instrument has a limited warranty against defective materials and/or workmanship for two years from the date of purchase provided that, in the opinion of the factory, the instrument has not been tampered with or taken apart.

**Should your instrument fail due to defective materials, and/or workmanship during the two-year period, please have your dated bill of sale which must identify the instrument model number and serial number and call the number listed below:**

Service Division  
**AMPROBE INSTRUMENT**  
Miami, Florida 33150  
Tel: 800-327-5060

## CONTENTS

	PÁGINA
<b>LIMITED WARRANTY</b>	1
<b>SAFETY INFORMATION</b>	4
<b>A UNIQUE CLAMP-ON MULTIMETER</b>	6
• INTRODUCTION	6
<b>USING THE METER SAFELY</b>	8
<b>LCD DISPLAY ILLUSTRATION</b>	10
<b>GETTING ACQUAINTED WITH YOUR METER</b>	12
• ALIGNMENT MARKS	12
• ROTARY SWITCH	13
• INPUT TERMINAL	14
• PUSH BUTTONS	15
<b>PUSH-BUTTONS OPERATIONS</b>	16
<b>POWER ON OPTIONS</b>	18
<b>SPECIAL FUNCTIONS INSTRUCTIONS</b>	19
• Dynamic Recording	19
• Data Hold	22
• Zero (Relative)	
• Analog Bargraph	23
• Auto Power Off and Sleep Mode	24
• Disable Auto Power Off	25
• Demonstrate Annunciator	25
• Continuity Function For Ohms Measurement	26
• 1 ms Peak Hold	27

**CONTENTS continued**

	PAGE
<b>HOW TO OPERATE</b>	
• AC CURRENT MEASUREMENT	29
• DISTRIBUTION TRANSFORMER MEASUREMENT	29
• AC MOTOR CURRENT MEASUREMENT	31
• AC VOLTAGE MEASUREMENT	33
• RESISTANCE / CONTINUITY MEASUREMENT	35
• TEMPERATURE MEASUREMENT	39
• CAPACITANCE MEASUREMENT	43
<b>ESPECIFICACIONES GENERALES</b>	45
<b>GENERAL SPECIFICATIONS</b>	47
<b>ACCESSORIES AND REPLACEMENT PARTS</b>	48
<b>CURRENT HARMONICS THEORY</b>	51
• TRUE RMS MEASUREMENT	53
• WAVE FORM COMPARISON	54
<b>REFRIGERATION</b>	56
<b>MAINTENANCE</b>	61
• SERVICE	61
• BATTERY REPLACEMENT	61
• CLEANING	64

## SAFETY INFORMATION

### SAFETY INFORMATION:

- To ensure that you use meter safely, follow the safety guidelines listed below.
- This meter is for indoor use, altitude up to 2000m.
- Avoid working alone. Take precautions when working around moving parts.
- Use the meter only as specified in this manual. Otherwise, the protection provided by the meter may be impaired.
- Never measure current while the test leads are inserted into the input terminals.
- Do not use the meter if it looks damaged.
- Inspect the leads for damage insulation or exposed metal. Check test lead continuity. Replace damaged leads
- Disconnect the power and discharge all high-voltage capacitors before testing.
- Use caution when working above 60V DC or 30V AC RMS. Such voltages pose a shock hazard
- When making measurements, keep your fingers behind the finger guards on the probe.

- Set the proper function and range before attaching the meter to circuit. To avoid damaging the meter disconnect the test leads from test points before changing functions.
- Read this operation manual completely before using the meter and follow all safety instructions.
- The meter is safety-certified in compliance with UL3111-1, C22.2 NO.1010.1-92 and EN61010(IEC 1010-1, 1010-2031, IEC 1010-2-32) Installation Category II 1000V or installation Category III 600V. In order to maintain its insulation properties, please be sure to use UL Listed Category II 1000V or Category III 600V probes.
- Installation category (CAT) II is an environment with smaller transient overvoltage than Installation Category III.
- CE requirement: Under the influence of R.F field according to standard, the supplied test leads will pick up induced noise. To have better shielding tests are required in order to conform to CE:
  1. IEC 801-2: ESD (electro-static discharge) test.
  2. IEC-801-3: RFI (Radio frequency Interference) test.  
Condition : 27 ~ 500MHz, signal intensity is 3 volts per meter.
  3. IEC 801-4: EFT (electro-fast transient) test.
  4. EN 55011: EMI (electromagnetic interference) test.
- Do not allow the temperature sensor to contact a surface which is energized above 30 V RMS or 60V DC, such voltages pose a shock hazard.

## AUNIQUE CLAMP-ON MULTIMETER

### □ INTRODUCTION

Measuring current accurately is difficult job in today's industrial plants and commercial buildings. An increasing number of personal computers, adjustable speed motor drivers, and other types of electronic equipment in short pulses and are referred to as non-linear loads.

non-linear loads draw high peak current, causing harmonics in the load current. this may result in unexplained circuit breaker tripping, or dangerous overheating of neutral conductors and transformers. Currents containing harmonics can only be accurately measured with a true rms or clamp meter. this CLAMP-ON MULTIMETER is shown in **Figure1**.

This meter has many functions which are shown below:

- **TRUE RMS measurement for non-linear and traditional loads.**
- **1ms Peak. Hold feature to capture glitch or in-rush current.**
- **Differentiation reading for Dual temperature measurement.**
- **Start capacitor measurement.**
- **Dynamic Recording helps to record the variation of test.**
- **Hand Guard for prevention of accidental contact with conductors.**
- **Carrying case with shoulder strap**
- **Data Hold to freeze displayed digital value.**
- **Relative(zero) function**
- **Auto and Manual Ranging**



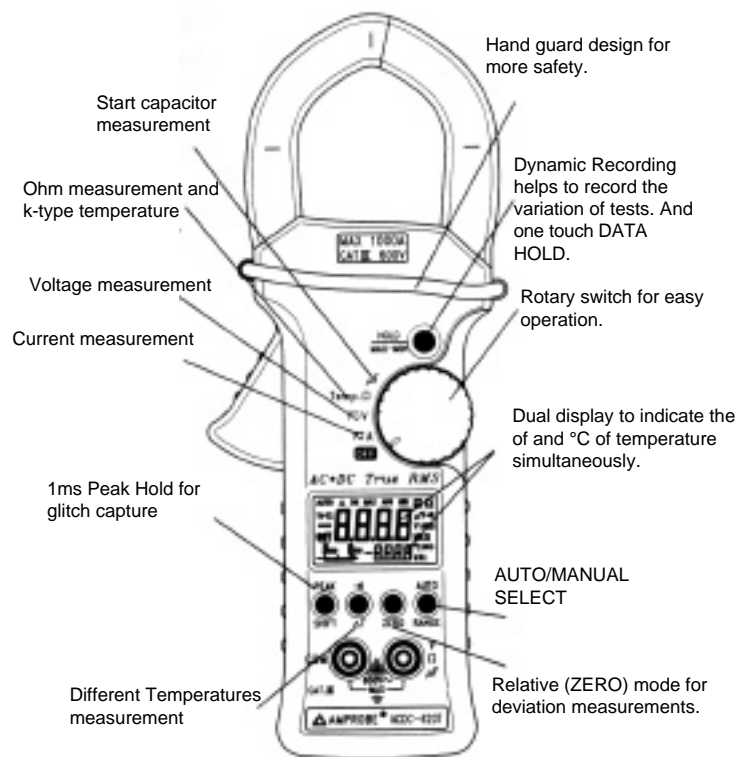

**Figure 1. A Unique Clamp-On Multimeter**

## USING THE METER SAFELY

### ☐ **WARNING**

Read " SAFETYINFORMATION" before using the meter..

### ☐ **NOTE**

Some typical tests are provided in this manual. These tests are designed to help you understand how to use the Meter. Consult original manufacturer service manual for the test procedures that apply to your particular piece of equipment.

Your Clamp-on multimeter is a hand-held, battery operated instrument for testing and troubleshooting electrical and electronic systems. If the meter is damaged or something is missing, contact the place of purchase immediately.

A **WARNING** identifies conditions and actions that pose hazard(s) to the user; a **CAUTION** identifies and actions that may damage the Meter. International electrical symbols used are explained in **Table 1**.

~	AC- Alternating Current
—	DC- Direct Current
⎓	AC and DC-Alternating and Direct Current
⏏	Ground
□	Double Insulation
⚠	See Explanation In The Manual

Tabla 1. Símbolos Eléctricos Internacionales

## LCD DISPLAY ILLUSTRATION



- |     |   |  |
|-----|---|--|
| 1)  | -   | Negative polarity Annunciator                      |
| 2)  | @OFF  | Auto Power Off Enabled Annunciator                 |
| 3)  |              | Low Battery Annunciator                            |
| 4)  | DC  | Direct Current or Voltage Annunciator              |
| 5)  | AC  | Alternating Current or Voltage Annunciator         |
| 6)  | AUTO  | AUTOrange Mode Annunciator                         |
| 7)  | DH  | Data hold Annunciator                              |
| 8)  | DH MAX  | Peak hold Annunciator                              |
| 9)  | MAX AVG MIN   | Dynamic recording mode, present reading            |
| 10) | MAX   | Maximum reading                                    |
| 11) | MIN   | Minimum reading                                    |
| 12) | AVG   | Average reading                                    |
| 13) | ·)))  | Continuity function annunciator                    |
| 14) | T1-T2   | Delta Temperature (withDKTA-620 adapter)           |
| 15) | T1 T2   | T1 or T2 temperature measurement                   |
| 16) | °C, °F  | Unit of temperature                                |
| 17) | V   | Unit of Voltage measurement                        |
| 18) | A   | Unit of Current measurement                        |
| 19) | kW  | Unit of Resistance (ohm) measurement               |
| 20) | —   | Zero (Delta) mode annunciator                      |
| 21) | 8.8.8.8   | Digital display for degree °F, A, V and            |
| 22) |  8000 8000 | Analog bar-graph annunciator with scale indicator. |
|     |            |  |
| 23) | µF  | Unit of Capacitor measurement                      |
| 24) | - 8.8.8.8   | Digital display for degree C                       |



Figure 2. LCD Display

## Getting Acquainted With Your Meter

### □ ALIGNMENT MARKS

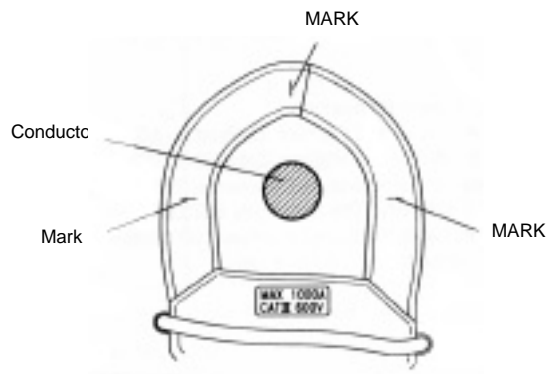

**Figur3 3. Alignment Marks**

In order to meet the meeter accuracy spacifications when making a current measurement, the conductor must be inside the jaws and centered within the indicated marks as much as possible (see Figure 3).

### Rotary Switch

To turn the meter on and select a function, turn the rotary switch (Figure 4) to a switch setting. The whole display lights for one second.

Then the meter is ready for use. (if you press and hold down any push button while turning the meter from OFF to ON, the display remains [it until the push button is released.]

1. **OFF**: Power off position.
2. **A**: AC or DC Current. Default is AC current.  
**El valor predetermina. do es corriente alterna (CA).**
3. **V**: AC or DC voltage. Default is AC voltage.
4. **Temp** : Temperature/Differential Temperature, Ohms, and Continuity. The continuity buzzer sounds when test value that is displayed is below 100 counts.
5.  $\mu\text{F}$ : Capacitance measurement.

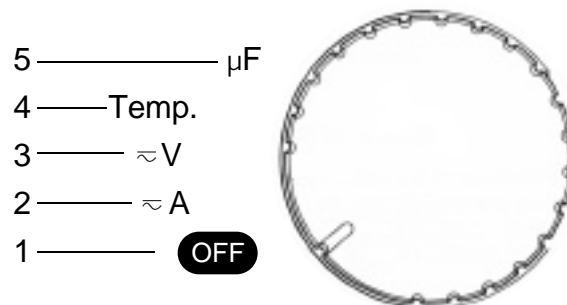

Figure 4. Rotary Switch

## INPUT TERMINAL

### WARNING

To avoid damaging the meter, do not exceed input limit shown below  
**Table 1:**

ROTATORY SWITCH FUNCTION	INPUT TERMINAL	INPUT LIMIT
AC 400 ~ 1000V (CAT II) AC 400 ~ 600V (CAT III)	V - $\mu$ F & COM	CAT II 1000V de CA/1000V DC  CAT III 600V
DC 400 ~ 1000V (CAT II) DC 400 ~ 600V (CAT III)		
DC 400 ~ 1000 A AC 400 ~ 1000 A OHM ( )	Clamp jaw	1000 ARMS
Capacitance ( $\mu$ F) Temperature	V - $\mu$ F & COM	600V RMS

**Table 1. Input limit specification Table 1.**

The meter has two input terminals (Figure 5) that are protected against overloads to the limits shown in the specifications.

1. Terminal común para todas las mediciones excepto la de corriente.
2. Voltios, Ohmios, Prueba de Capacidad y mediciones de Temperatura.

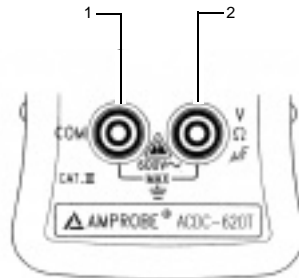

**Figure 5. Input Terminal**

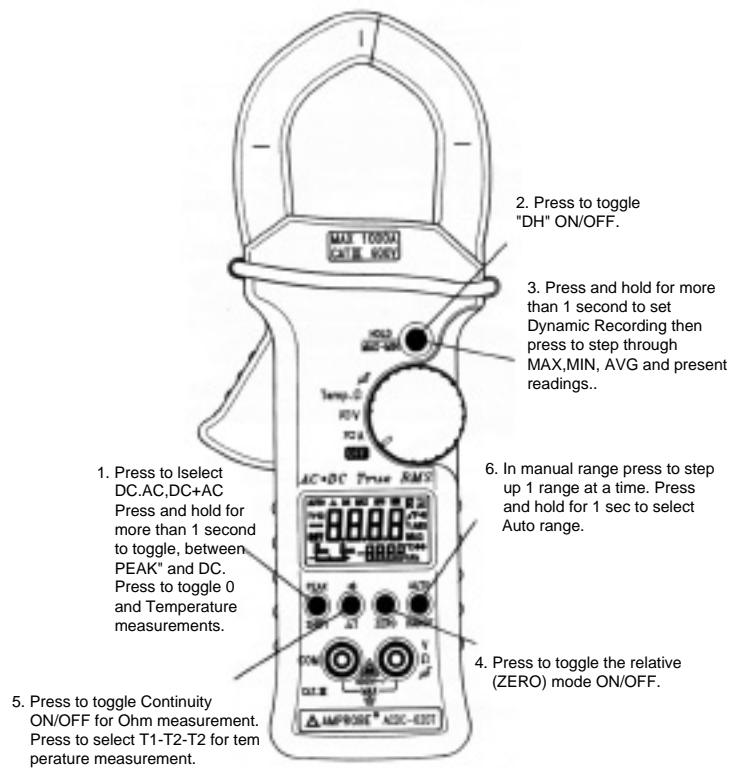

**Figure 6. Push buttons**



## Push-button Operations

The operation of the push-buttons are outlined below. When a button is pushed, an annunciator lights, and the unit beeps. turning the rotary switch to another switch setting resets all push buttons to their default states. The pushbuttons are shown in (page15).

### 1. Shift / Peak $\odot$ :

- This push-button is used for selecting the measurement of either an Alternating or Direct source, Ohms or Temperature, or for selecting the PEAK hold function.
- Press this button momentarily to toggle DC and AC test. or between and Temperature.
- To select PEAK hold, press and hold this button until the display shows " DH MAX" and indicates the PEAK hold mode.

### 2. Hold $\odot$ : Hold Q: DATAHOLD or Refresh Data Hold

The data HOLD function allows operator to freeze the displayed digital value while the analog bargraph continues to display the present reading.

Press this button momentarily to toggle DH on or off.

The display shows "DH" to indicate the hold function.

If you select " Refresh Data Hold " by Power-ON

Options, the reading is updated to the display automatically when the reading changes. The beeper sounds a tone to remind user, that an update has occurred. Press this button momentarily to toggle DH on or off.

. MAX \* MIN 0: Dynamic Recording

### 3. MAX • MIN $\odot$ : Dynamic recording

- To enter or exit dynamic recording mode, press and hold this button to toggle recording mode, press and hold this button to toggle recording mode on or off.
- Records maximum, minimum, and calculates true average.
- Press this button momentarily to cycle through maximum, minimum, average and present (**MAX AVGMIN**) readings.

4. **Zero**  $\odot$ :

- Push this button momentarily to zero the residual current. Note: Allow the meter to stabilize before zeroing the display. The " " will also be displayed.

5.  $\bullet$ ) / **Tm**: continuity, Delta Temperature

- In the position, press this button momentarily to toggle " $\bullet$ )"
- continuity ON/OFF. The continuity buzzer sound when test value is below 100 counts (10,0 on auto range). pushing this button for more than 1 second will exit the continuity function and return to the auto-ranging ohm measurement.
- Press to restart 1ms PEAKhold test after entering PEAK mode.
- in the temperature test, push this button momentarily to toggle between **T1 T2** temperature and **T1 - T2** differential temperatures test. Note: **T1, T2** or **T1 - T2** selected on the **DKTA-620** accessory adapter (optional)..

6. **AUTO / RANGE**  $\odot$ :

- In auto-range press this button momentarily to select manual range and turn off the "**AUTO**" annunciator.
- In manual range, press this button momentarily to step up 1 range at one time, press. this button for more than 1 second to enter auto-range.
- in auto-range, the "**AUTO**" annunciator is lit and the meter will select an appropriate range for measurement being made. If a reading is greater than maximum available range, "**OL**" (overload) is displayed on the screen. The meter selects a lower range when reading is less than about 9% of full scale.

## POWER-ON OPTIONS

### □ SELECTING POWER-ON OPTIONS

Some options can only be selected when you turn the meter on. These power-on options are listed in **Table 2**.

To select power-on press and hold the appropriate pushbutton while turning the rotary switch to any ON position. Power-on options remain selected until the meter is turned off.

PUSH BUTTON	OPTIONDESCRIPTION
DH ○ MAX ● MIN	<p><b>Demonstrate Annunciators</b></p> <p>To demonstrate the annunciators. to demonstrate all annunciators. momentarily press any button to exit the demonstration mod.</p> <p><b>Disable auto-power off</b></p> <p>In general, the auto-power off function turns the meter off if neither rotary switch nor push button is activated for 15 minutes. You can disable auto-power off function by this option. When auto-power off is disabled the meter will stay in on continuously. Auto-power off is auto disabled in Dynamic Recording.</p> <p><b>Enable "Refresh data Hold".</b></p>
●))) ○ T	<p>Turns off all beeper functions.</p>

**Table 2. Power-ON Options**

## SPECIALFUNCTIONS INSTRUCTIONS

This clamp-on multimeter provides the operator with various functions including:

- Dynamic Recording**
- Data Hold**
- Zero (Relative)**
- Analog bargraph**
- Auto Power Off and Sleep Mode**
- Disable Auto Power Off**
- Demonstrate Annunciator of Display**
- Continuity Function For Ohms Measurement**
- 1ms Peak hold**

### **DYNAMIC RECORDING**

The dynamic recording mode can be used to catch intermittent and turn on or off surges, verify performance while you are away, or take readings while you are operating the equipment under test and can not watch the meter.

the average reading is useful for smoothing out unstable or changing inputs, estimating the the percent of time a circuit is operational, or verifying circuit performance

The operational procedures are described below::

1. Press and hold the "**MAX•MIN**" push button to toggle recording mode on or off. the dynamic recording ode is indicated when the **MAX AVG MIN** annunciator turns on. The present value is stored to memories of maximum, minimum and average.
2. Press this button momentarily to cycle through maximum, average and present readings. The **MAX, MIN, AVG** annunciator turns on respectively to indicate what value is being displayed. See **Figure 7**.

3. The beeper sounds when a new maximum or minimum value is recorded.
4. If an overload is recorded the averaging function is stopped. An average value becomes "OL" (overloaded).
5. **In dynamic recording the auto power off feature is disabled and the "@OFF" turns off.**
6. By selecting dynamic recording in the auto range, the meter will record the value of MAX, MIN or AVG for different ranges.
7. The record speed of dynamic recording is about 100 milli-seconds (0.1 second).
8. The average value is the true average of all measured values taken since the recording mode was entered.

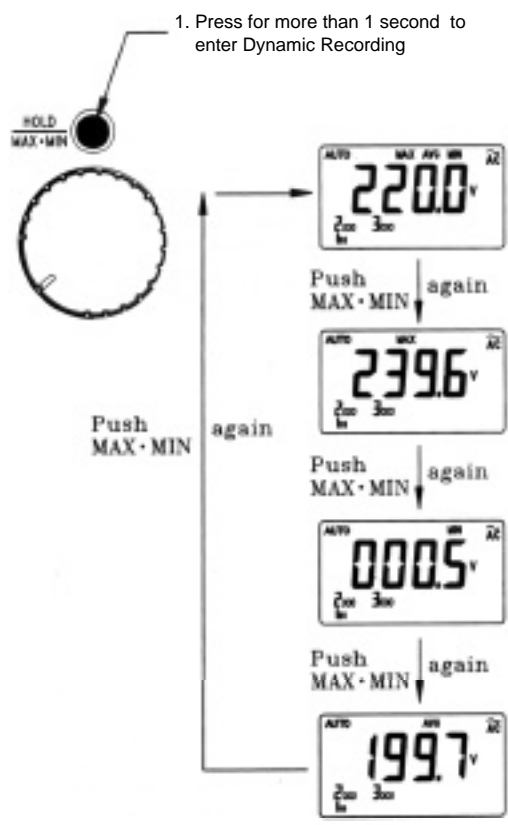

Figure 7. Display of Dynamic Recording

#### DATAHOLD

The data HOLD function allows operator to freeze the displayed digital value while the analog bargraph displays present readings. Press "DH" Hold button to enter the data Hold mode, and the "DH" annunciator is displayed. Press the button again to exit. The present reading is now shown.



Figura 8. Operación de Retención de Datos (Data Hold)

#### ZERO (RELATIVE)

The ZERO (relative) function subtracts a stored value from the present measurement and displays the result..

- 1) Press the ZERO button momentarily to set the relative mode. This sets the display to zero and stores the present reading as a reference value. The " " annunciator will also be displayed. Press this button again to exit the relative mode.
- 2) The ZERO (relative) mode can be set in both the autorange or manual range mode. The relative mode can't be set when an overload has occurred.
3. When the Dc Current measurement mode is entered, the display will indicate a non-zero DC Current (positive or negative) value due to residual magnetism of the jaw and of the internal sensor. You can use the Zero (relative) function to Zero-Adjust the display.

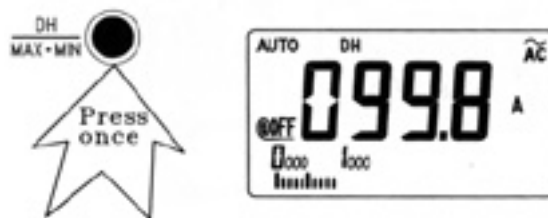
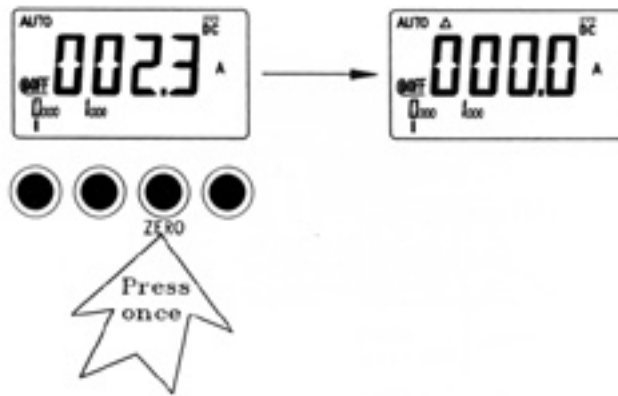

Figure 9. relative(Zero) Operation.

□ ANALOGBATRGRAPH

The analog bargraph display provides a 12-segment analog reading representation. The unit of the bargraph is 100 counts/bar.





Figura 10. Analog Bar graph

□ **AUTO POWER OFF AND SLEEP MODE**

There are two modes for power saving.

- 1) The instrument will enter the "sleep" mode within 15 minutes, unless:
  - 1-1. Any push buttons have been pressed
  - 1-2. The rotary switch has been changed to another function
  - 1-3. The unit has been set to Dynamic recording mode
  - 1-4. The unit has been set to 1 ms PEAK hold mode.
  - 1-5. The auto power off has been disabled with powerup option
- 2) In the sleep mode, the LCD will display a blinking "@OFF . . ." annunciator.
  - 2-1. To wake-up sleep mode, press any push button for 0.5 sec or rotate rotary switch.
  - 2-2. Without wake-up, after 15 minutes, the meter will automatically shut off completely.
- 3) You must turn the rotary switch to the OFF position, then turn it back to a function to activate the meter after an auto power off.

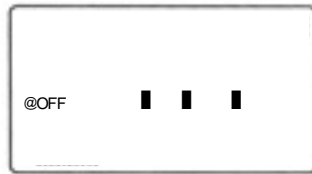

**Figure 11. Sleep Mode**

**DISABLE AUTO POWEROFF**

When the meter is to be used for long periods of time you may want to disable the auto power off. Once the auto power off function is disabled, the meter will stay on continuously. The meter is shut off by turning the rotary switch to the OFF position.

To activate this function, press and hold the "**HOLD/MAX • MIN**" button and turn the rotary switch from the OFF position to the desired function. When all annunciators are displayed, press any button momentarily to exit demonstrate mode, and the "@OFF" annunciator will be off.

**DEMONSTRATE ANNUNCIATOR**

To demonstrate the annunciators, press "**HOLD/MAX • MIN**" button and turn on the meter simultaneously. All annunciators will be displayed. Press any button to exit demonstrate mode. Auto power off will be disabled.

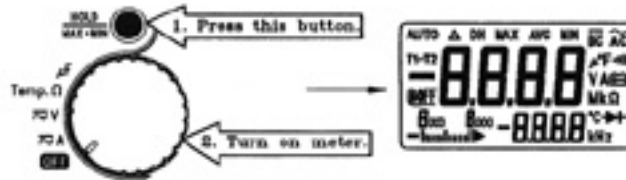

Figure 12. Demonstrate Annunciator.

CONTINUITY FUNCTION FOR OHMS MEASUREMENT

To enable the continuity function, set the meter to the  $\Omega$  range.  
 Press  $\rightarrow$  button momentarily to toggle the CONTINUITY function ON/OFF.

The continuity range is 0-400.0  $\Omega$  and the beeper will sound if the resistance is less than 10.0  $\Omega$ . If another range is selected, the unit will beep if the value displayed is less than 100 counts. Momentarily pushing this button again will toggle the beeper and annunciator on or off.

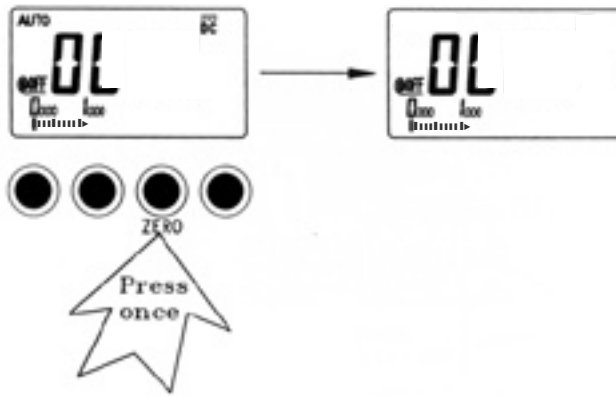

Figure 14. Continuity Operation

**1ms Peak Hold**

You can use this Meter to analyze components such as power distribution transformers and power factor correction capacitors. The additional features allow the measurement of the half-cycle peak current by using the 1 ms peak hold feature. This allows the determination of the crest factor:

**Crest factor = Peak value/True rms value**

- 1) Press **PEAK** button for more than 1 second to toggle 1 ms peak hold mode ON/OFF.
- 2) Press **PEAK** button momentarily to select PEAK+ measurement after entering the peak mode. The display shows "DH MAX" to indicate the PEAK +. **See Figure 16.**

- 3) If the reading is "OL", then you can push **RANGE** button momentarily to change measuring range and restart the PEAK+ measurement after setting the peak mode.
- 4) Press **•**) button to re-set the 1 ms peak hold again after setting peak mode.

Note: Acrost factor of 1.4 indicates a sinusoidal waveform.

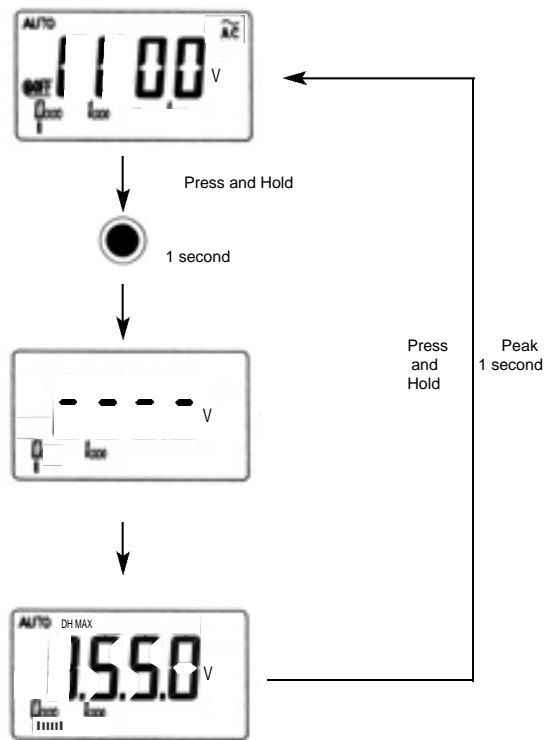

Figure 16. 1ms Peak Hold Display.

## HOW TO OPERATE

### AC CURRENT MEASUREMENT

**WARNING:** MAKE CERTAIN THAT ALL TEST LEADS ARE DISCONNECTED FROM THE METER TERMINALS.

- 1) Set the rotary switch to " A ".
- 2) Open the meter jaws and clamp around a single conductor. The most accurate reading will be obtained by keeping the conductor aligned with the centering marks on the jaws. Make sure that the jaws are fully closed.
- 3) Read the display.

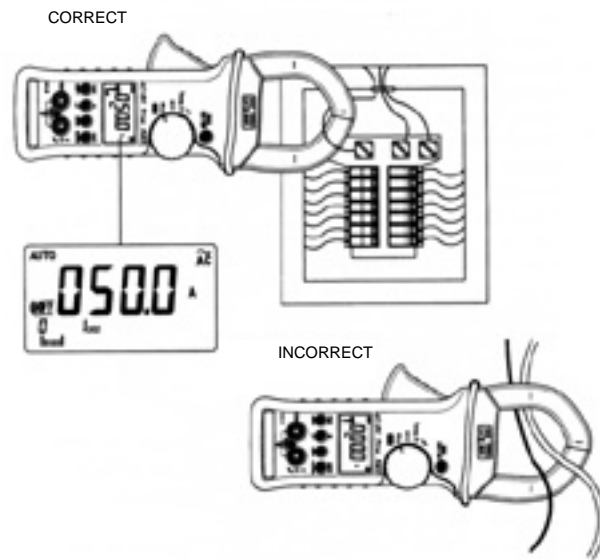

Figure 17. Measuring AC Current.

#### □ DISTRIBUTION TRANSFORMER MEASUREMENT

You can measure current, phase imbalance between phases, and true RMS neutral current. True RMS measurement yields the effective value.

- 1) Set the rotary switch to " **A** ".
- 2) Clamp around a phase wire of the transformer. Be sure the jaws are completely closed or measurement will not be accurate.
- 3) Observe the display for true RMS current.
- 4) Repeat your measurement for each phase to determine balance. Imbalanced phases and/or harmonics can cause neutral currents.
- 5) Observe the display for true RMS current reading. If the phases are balance, any significant current flow on the neutral may indicate the presence of harmonic currents.
- 6) Press the **HOLD/MAX ● MIN** button to freeze the digital display.
- 7) Press and hold the **SHIFT** button (>1 sec) to enter the PEAK mode (**DH MAX** displayed). Measure the half cycle PEAK current. Divide first reading into the second reading to determine crest factor. A crest factor other than 1.4 is an indication of harmonic current.
- 8) Press and hold the **SHIFT** button (>11 sec) to exit the PEAK mode.
- 9) Press and hold the **HOLD/MAX ● MIN** (> 1 sec) to enter dynamic recording mode. Momentarily press **HOLD/MAX ● MIN** button to review recorded maximum, minimum, and average values.
- 10) Press and hold the **HOLD/MAX ● MIN** button (> 1 sec) to exit recording.



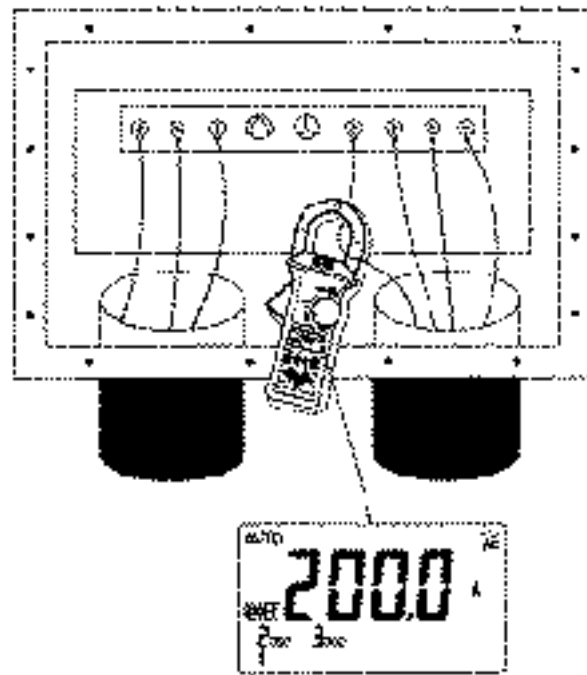

Figure 18. Measuring AC Current

#### □ AC MOTOR CURRENT MEASUREMENT

You can measure starting (inrush) current, running current, and current imbalance in AC Motor circuits. Inrush current is typically 6-8 times the value of running current, depending on the motor type..

1. Set the rotary switch to "A".
2. Press and hold the **PEAK** button(>1sec) to enter 1ms PEAK hold mode.
3. Clamp around a motor phase conductor. Be Sure the clamp jaws are completely closed, or measurement will not be accurate..
4. Press **ZERO** to set the display to zero.
5. Turn the motor on. When the motor gets to the desired speed, observe the display for inrush current reading.
6. If the reading is "OL", you can push the **RANGE** button momentarily to change measuring range. Turn off the motor.
7. Repeat your measurement from step 2 through 6 for each phase. A voltage imbalance or a shorted motor winding may cause imbalance current..

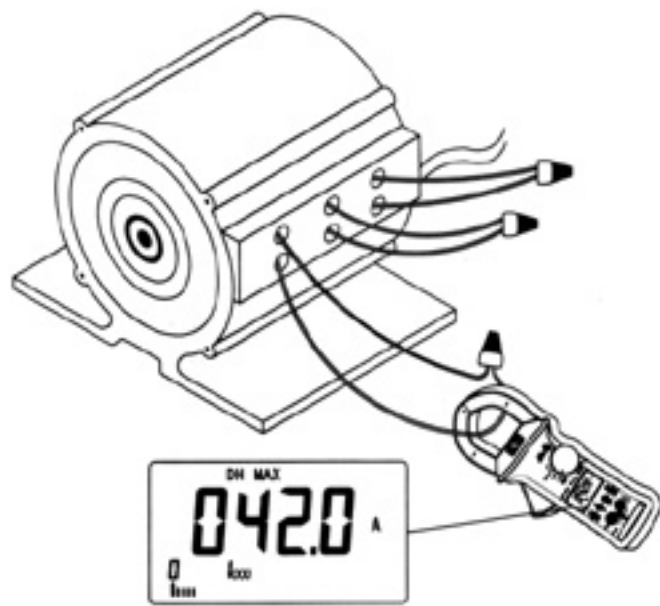

Figure 19. Measuring AC Motor Current

□ **AC VOLTAGE MEASUREMENT**

1. Set the rotary switch to "V".
2. Insert the black test lead to "**COM**" terminal and red test lead to "V -  $\mu$ F" terminal.
3. touch the probes to the test points and read the displayed AC Voltage.

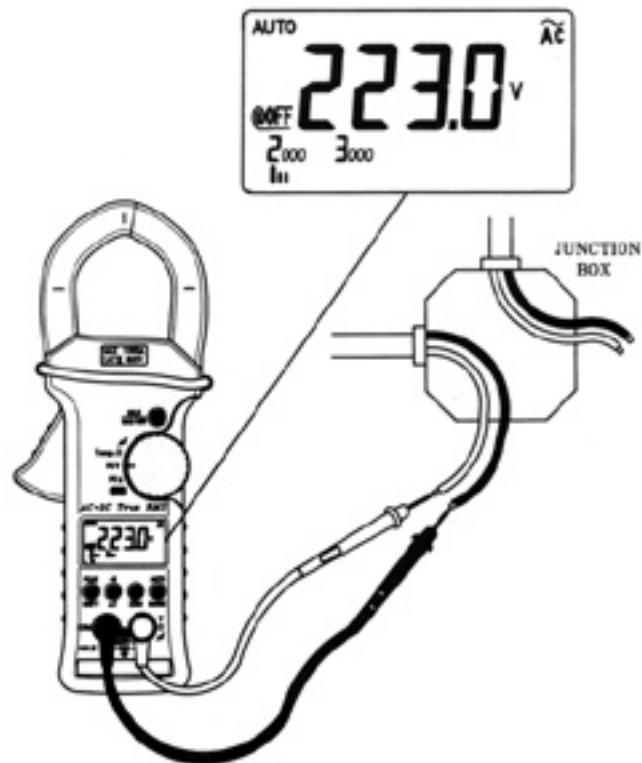

Figure 20. Measuring Voltage.

□ RESISTANCE / CONTINUITY MEASUREMENT

**CAUTION:** Make sure that power is removed and all capacitors have been discharged before measuring.

- 1) Set the rotary switch to "**TEMP.**". OL is displayed.
- 2) Insert the black test lead to "**COM**" terminal and red test lead to "**V -  $\mu$ F**" terminal.
- 3) Short the test leads together and momentarily press the **ZERO** button to subtract test lead resistance from measurement.
- 4) Touch the test leads to the circuit (Fuse Cartridge or other) and read resistance value in the display.
- 5) Press **•**) button momentarily to enter continuity function if desired.
- 6) Repeat steps 3 and 4. The beeper sounds if continuity reading is less than 10.0 . .
- 7) **OL** (overload) is displayed if the resistance across the input terminals is greater than the full-scale rating on the range setting of the instrument. Be sure that the contact between the probes and the circuit is clean. Dirt, oil, paint, rust or other foreign matter can seriously effect resistance measurements.



Figura 21. Measuring Resistance and Continuity.

## TEMPERATURE (K-TYPE) MEASUREMENTS

The ACDC-620TLCD contains a dual display for Temperature Measurement. The larger digits display °F (Fahrenheit), and the small digits display °C (Celsius). Both readings are displayed simultaneously.

**CAUTION:** Do not allow the temperature sensor to contact a surface which is energized above 30 V RMS or 60 V DC, such voltages pose a shock hazard.

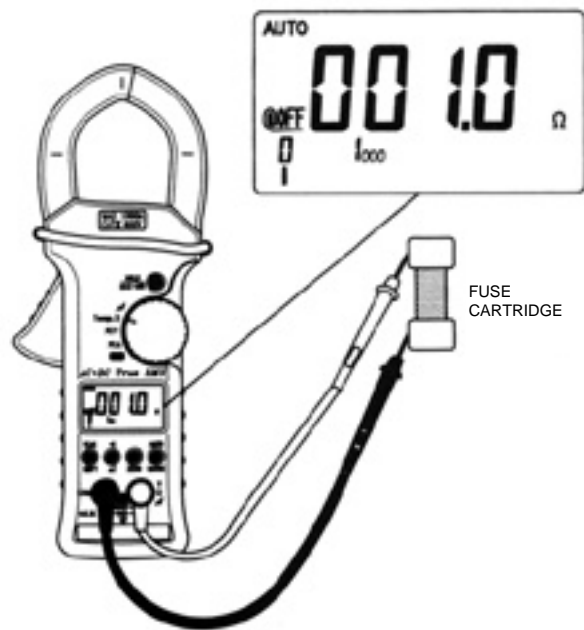
• To perform single input temperature measurement:

- 1) Set the rotary switch to "TEMP. ",
- 2) Insert the model TAC-DMM banana to K-type thermocouple adapter into the meter. The "+" end of adapter must be inserted into "V - -  $\mu$ F" terminal.
- 3) Insert the model TPK-56 Type K thermocouple into the TAC-DMM.
- 4) Secure the beaded end of the K thermocouple to the surface you wish to measure.
- 5) Press **SHIFT** button momentarily to enter temperature measurement mode.
- 6) Read the displayed temperature.



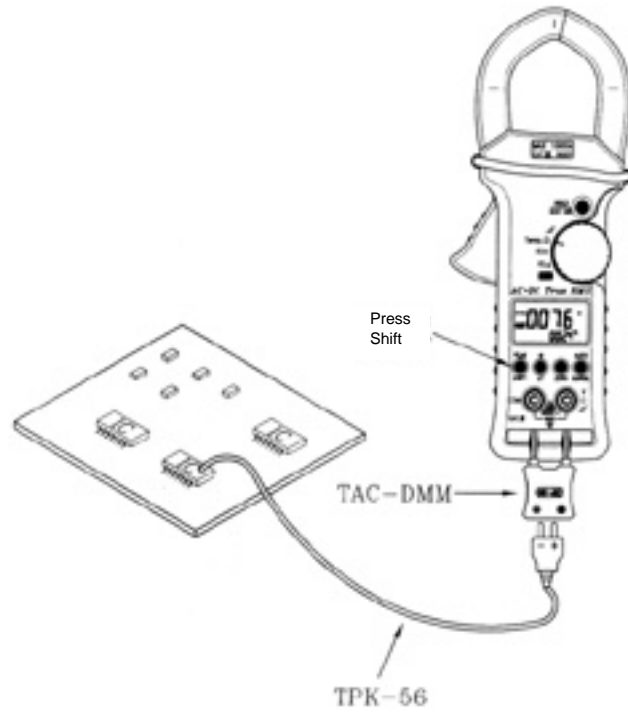

Figure 22. Surface Temperature Measurement.

- To perform dual input and/or differential temperature measurement:

- 1) Set the rotary switch to "**TEMP.**".
- 2) Insert the model DKTA-620 Dual Type K thermocouple adapter into the meter.  
The "+" end of the adapter must be inserted into "V -  $\mu$ F" terminal.
- 3) Insert two of the model TPK-56 Type K thermocouples into the DKTA-620.
- 4) Secure the beaded end of the K thermocouples to the surfaces you wish to measure.
- 5) Press **SHIFT** button momentarily to enter temperature measurement mode.  
The "**T1 T2**" annunciator will be displayed.
- 6) Since the displayed temperature will be based on the position of the selector switch located on the DKTA-620 adapter, select either T1 or T2 for the desired measurement.
- 7) Read the display.

- To measure differential temperature:

**Note:** T1 temperature must be greater than T2 for differential measurement to be correct.

- 1) Set the DKTA-620 selector switch to the "**T1-T2**" position.
- 2) Push the **T** button on the ACDC-620 momentarily to enter the Differential Temperature Mode. The "**TI-T2**" and "A" annunciators will be displayed.
- 3) Read the displayed differential temperature.
- 4) For information on basic refrigeration theory refer to page 56.

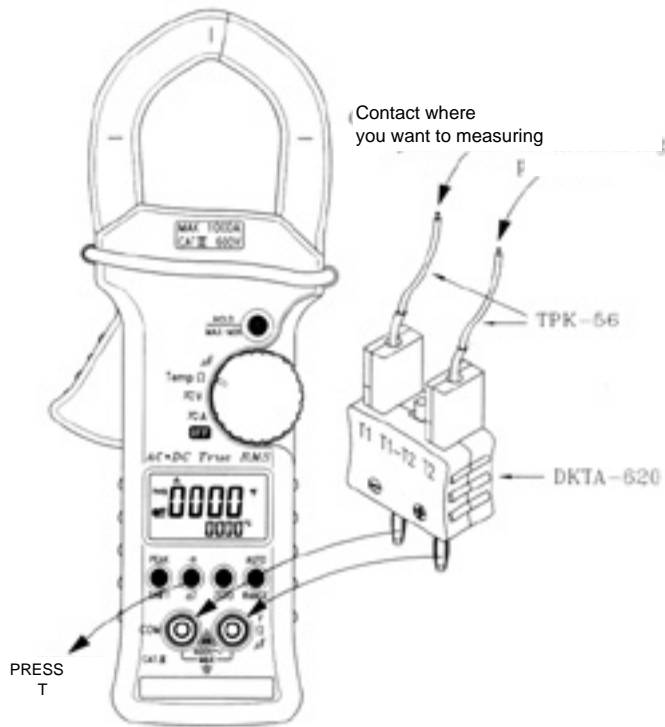

Figure 23. Measuring Temperature on Refrigeration System.

□ **CAPACITANCE MEASUREMENTS**

In many instances a motor can not be started due to a failed start/run capacitor. To test the capacitor:

: Discharge the capacitor before testing.

- 1 ) Set the rotary switch to " $\mu\text{F}$ " position.
- 2) Insert the black test lead to "**COM**" terminal and red test lead to "**V -  $\mu\text{F}$** " terminal.
- 3) Remove at least one leg of the capacitor from circuit board or device.
- 4) Touch the test leads across the capacitor and read the display.

**Note:** If you are measuring a polarity sensitive electrolytic capacitor, touch the red test lead to the positive end of the capacitor, and the black test lead to the negative end of the capacitor.

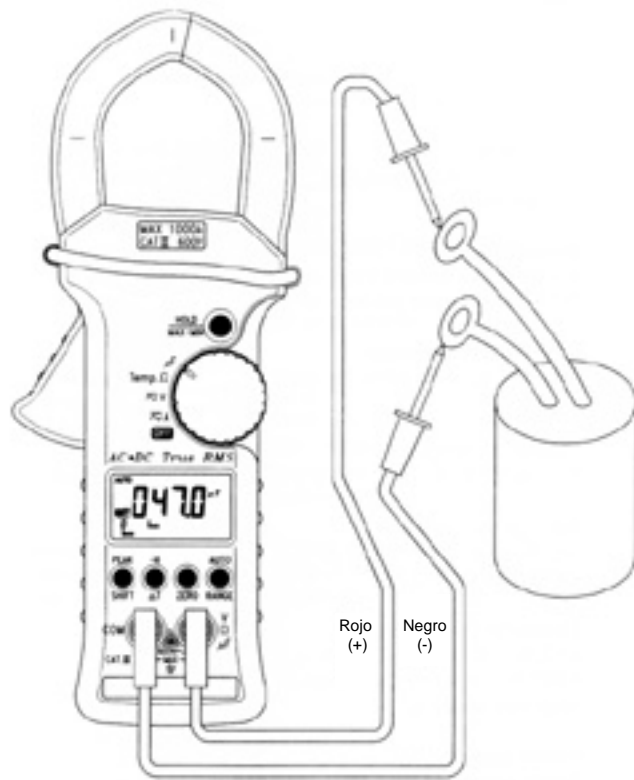

Figure 24. CAPACITANCE MEASUREMENTS.

## GENERAL SPECIFICATIONS

**Display:**

Display: Fully annunciating 4-digit liquid crystal display (LCD) with maximum reading of 4,000 count. Dual display in Temperature mode. 12 segments analog bar graph. Automatic polarity indication.

**Functions:** DCV, ACV, DCA, ACA, OHM, Capacitance and Temperature.

**Measuring rate:**

3.3 times per second for V, A, Ohm and Temperature tests.  
0.5 - 7.6 seconds per time for Capacitance test.

**Low battery indicator:**

The "⎓" appears when the battery voltage drops below 7V (approx.).

**Operating temperature:**

0 °C to 50 °C (32 °F to 122 °F), 0 - 80% R.H.

**Storage temperature:**

-20°C to 60 °C (-4°F to 140 - F), 0 - 80% R. H. with  
BATTERYREMOVED.

**Temperature coefficient:**

0.12 % / °C (from 0°C to 18 °C or 28 °C to 50 °C),  
0.067 % / °F (from 32 °F to 64.4 °F or 82.4 °F to 122 °F), or  
otherwise specified.

**Power supply:** Single standard NEDA1604, JIS006P, IEC6F22 carbonzinc or alkaline type 9V battery.

**MAX. Jaw Opening:**

To Accommodate Circuit Cables 2" ( 50.8 mm ) diameter.

**Dimension:**

32 (H) x 64 (W) x 260 (L) mm  
1.26"(H) x 2.52"(W) x 10.24"(L)

**Weight:** 840 grams with battery included. (1.85 lbs with battery included.)

**Standard Accessories:** Test leads (pair), Manual, Battery and Carrying case.

**Optional Accessories:** K-type bead probe and Dual input adopter.

**Safety:** Designed and manufactured to conform to UL3111-1, C22.2 NO. 1010. 1 - 92 and EN61 010 (IEC1 010-1, IEC1010-2-031, IEC-1010-2-032) Installation Category (Overvoltage Category) 111 OOOV or Installation Category III 60OV, Pollution Degree 2 environment.

**Note:** Meter has been submitted for approval to above standard at the time of printing of this manual. Product will be marked accordingly upon approval.

**Accessories and ReplacementsParts**

<b>Amprobe P/N</b>	<b>Description</b>
DTL-3000	Safety Test Leads(included)
CC-ACDC	Carrying Case(included)
978760	Instruction Manual(included)
MN-1604	9 Volt Alkaline Battery(included)
DKTA-620	Dual input thermocouple adapter(opcional)
TAC-DMM	Single input thermocouple(opcional)
TPK-56	Type K bead probe(opcional)



## ELECTRICAL SPECIFICATIONS

Accuracy is given as  $\pm$  % of reading + the number of least significant digits at 23°C  $\pm$  5°C, with relative humidity Less than 80% R.H.

### DC VOLTAJE

Range	Resolution	Accuracy	Overload Protection
400V	0.1V	$\pm(1\% \text{ rdg} + 3 \text{ dgt})$	1000V AC RMS
1000v	1V		

- Input Impedance: 10M .

### AC Voltage

(TRUE RMS: From 10% at 100% of range)

Range	Resolution	Accuracy 45Hz ~ 400 Hz	Overload Protection
400V	0.1V	$\pm(1,5\% \text{ rdg} + 3 \text{ rdg})$	1000V AC RMS
1000v	1V		

- Input Impedance: 10M // less than 100pF.  
crest Factor: <3:1

### VOLTAGE ( 1ms PEAKHOLD)

SPECIFIED ACCURACY +/- 40 Digits for Changes >1ms in duration .

Range	Resolution	Accuracy	Overload Protection
400V	0.1V	$\pm(1\% \text{ rdg} + 3 \text{ rdg})$	1000 Voltios CA Eficaces (RMS)
1000v	1V		

- Input Impedance: 10M .

**DC CURRENT**

Range	Resolution	Accuracy
400A	0.1A	$\pm(1,5\%rdg+3rdg)$
1000A	1A	$\pm(2\% rdg+ 5rdg)$

**AC CURRENT**

(TRUE RMS: From 10% al 100% of range)

Range	Resolution	Accuracy	
		45Hz~65Hz	65Hz~2kHz
400A	0.1A	$\pm(2\% rdg+5dgt)$	$\pm(3\%rdg+5 dgt)$ $\pm(3\%rdg+5 dgt)$
1000A	1A	$\pm(2.5\% rdg + 5dgt)$	$\pm(3\% de la$

- Crest Factor: <3:1

**CORRIENTE (RETENCIÓN DE PICO DE 1ms)**

Precisión especificada  $\pm 40$  dígitos para cambios con duración mayor de 1ms.

Range	Resolution	Accuracy
400A	0.1A	$\pm(2\%rdg+ 43dgt)$
1000A	1A	$\pm(2\%rdg+43dgt)$

**VOLTAJE de CC**

Range	Resolution	Accuracy	Maximum Tets Voltage	Overload Protection
400	0.1	$\pm(1\%rdg+ 3dgt)$	3.3V	600V(RMS)
1000	1		1.25V	

- In continuity mode, built-in buzzer sounds when resistance is less than 10.0 .

**K-TYPE TEMPERATURE MEASUREMENT RANGE**

RANG	Resolution	Accuracy	*V Maximum
-40°C ~ 1372°C	1°C	±(0,5%rdg+3°C)	30 V RMS or 60 V DC
-40°F ~ 2502°F	1°F	±(0,5%rdg+6°F)	

**TEMPERATURE DIFFERENTIAL TYPE K**

Gama	Resolución	Precisión	*V Máximo
-50°C < T < 100°C	1°C	±(0,5%rdg+3°F)	30 V RMS or 60 V DC
-58°F < T < 180°F	1°F	±(0,5%rdg+6°F)	

**Note:** Do not allow the temperature sensor to contact a surface which is energized above 30 V RMS or 60 V DC, such voltages pose a shock hazard.

- The T1 input must be greater than -T2 input for T1-T2 measuring.
- the accuracy does not include the tolerance of thermocouple probe.
- MODEL PK-56, BEAD TYPE-K THERMOCOUPLE (optional)  
Temperature Rating (wire): continuous 204°C, 260°C (intermittent)  
Temperature measuring Range (bead): -50°C to +800°C (MAX) Accuracy.  
±2.2°C or ±0.75% of reading from 0°C to 800°C (whichever is greater)  
±2.2°C or ±2% of reading from 0°C to -50°C (whichever is greater)

**Caution:** The bead end can be touched to surface temperatures above 204°C for very short durations. However, wire insulation or wire may be damage if wire subjected to the same temperature.

**CAPACITANCE**

RANGE	Resolution	Accuracy	Overload Protection
400µF	0.1µF	±(3%rdg+4dgt)	600 V RMS
400µF	1µF	±(3.5%rdg+4dgt), >2mF, NO Spec	

- With film capacitor or better, use ZERO to cancel residual.
- Temperature coefficient: 0.15 x specified accuracy / °C (from 18°C or 28°C to 50°C) or 0.084 x specified accuracy / °F (from 32°F to 64.4°F or 82.4°F to 122°F)

## CURRENT HARMONICS THEORY

True-RMS current is very important because it directly relates to the amount of heat dissipated in wiring, transformers, and loads. Most clamp-on meters already in the field measure average current, not true RMS current, even if this average value is displayed on a scale calibrated in RMS. These average-sensing meters are accurate only for sinusoidal signals.

All current signals are distorted in some way. The most common is harmonic distortion caused by non-linear loads such as office machines, medical equipment, personal computers, or speed controls for motors. Harmonic distortion causes significant currents at frequencies that are odd multiples of the power line frequency. Harmonic current can cause a substantial load on the neutral wires of wye-connected power distribution systems.

In most countries, 50Hz or 60Hz power distribution systems include 3-phase delta primary - wye secondary transformers. The secondary generally provides 120V AC from phase to neutral, and 208V AC from phase to phase. Historically, balancing the loads on each phase was a big headache for the electrical system designer.

Typically, the vector addition of the phase currents in the transformers' neutral wire is zero or quite low in a wellbalanced system. Typical devices that present linear loading include incandescent lighting and small motors. The result is essentially a sine wave current in each phase and a low neutral current at a frequency of 50Hz: or 60Hz.

Devices such as TV sets, fluorescent lighting, video machines, and microwave ovens are now commonly drawing power line current for only a fraction of each cycle so that they cause non-linear loading and subsequent

non-linear current. This generates odd harmonics of the 50Hz or 60Hz line frequency. Therefore, the current waveform from the transformer could contain not only a 60Hz component, but also a 180Hz component, a 300Hz component, etc.

The vector addition in a properly balanced power distribution system feeding non-linear loads may still be quite low. However, the vector addition does not cancel all the harmonic currents. The odd multiples of the 3rd harmonic (called the "TRIPLENS") are added together in the neutral. These harmonics can create an RMS current in the transformers neutral wire that is 130% of the total RMS current measured in any individual phase. For example, phase currents of 80 amperes may cause 104 amperes of harmonic current in the neutral, the most common harmonic being the 3rd. The electrical designer must consider the following issues when designing a power distribution system that will contain harmonic current.

1. The AC neutral wires must be of sufficient gauge to allow for harmonic current.
2. The distribution transformer must have additional cooling to continue operation at its rated capacity. This is because the harmonic current in the secondary neutral wire is circulating in the deltaconnected primary winding. This circulating harmonic current heats up the transformer.
3. Phase current harmonics are reflected to the primary winding and they continue back towards the power source, This can cause distortion of the voltage wave so that any power factor correction capacitors on the line can be easily overloaded.

We can use this Meter to analyze components such as power distribution transformers and power factor correction capacitors. An additional feature allows the measurement of half-cycle peak current by using the 1 ms peak hold feature. This allows the ability to determine crest factor:

**Crest factor = Peak value/True rms value**

**NOTE: If Crest factor exceeds 1.1 harmonic distortion is present**

#### **TRUERMSMEASUREMENT**

The meter measures the TRUERMS value of AC voltages and currents. In physical terms, the RMS (Root-Mean-Square) value of a waveform is the equivalent DC value that causes the same amount of heat to be dissipated in a resistor. TRUE RMS measurement greatly simplifies the analysis of complex AC signals. Since the RMS value is the DC equivalent of the original waveform, it provides a reliable basis for comparing dissimilar waveforms.







By contrast, many meters use average-responding AC converters rather than TRUE RMS converters. The scale factor in these meters are adjusted so that they display the RMS value for a harmonic-free sine wave. If a signal is not sinusoidal, average-responding meters do not display correct RMS readings.

For a free video on Amprobe's Harmonalyzer, HA-2000 harmonic/waveform analyzer, please contact Amprobe directly.

□ **WAVEFORMCOMPARISON**

**Table3.** Illustrates the relationship between AC and DC components for common waveforms, and compares readings for TRUE RMS meters and average-responding meters. For example, consider the first waveform, a 1414V (zero-to-peak) sine wave. Both this Clamp-on meter and RMS-calibrated average-responding meters display the correct RMS reading of 100.0V (the DC component equals 0). However, consider the 200V (peak-to-peak) square wave, both types of meter correctly measure the DC component (0V). The clamp meter correctly measures the AC component (100.0V). The average-responding meter measures 111.1V, which amounts to an 11% error. The conversion factors in Table 3 show the differences between average sensing instruments and true RMS instrument measurements.

Table 3. WAVEFORM COMPARISON CHART

AC COUPLED WAVEFORM	PEAK VOLTAGE		METERED VOLTAGES			STANDARD 100% RMS
	FAVOR	OPR	ALL COMPONENTS FOR RMS CALC	DC COMPONENT ONLY	TRUE RMS VALUE	
	202.0	141.4	170.0	100.0	100.0	100.0
	141.4	141.4	142.1	94.5	100.0	100.0
	100.0	100.0	107.4	67.1	100.0	100.0
	100.0	100.0	114.4	50.0	100.0	100.0
	141.4	141.4	142.1	94.5	100.0	100.0
	100.0	100.0	107.4	67.1	100.0	100.0
	100.0	100.0	107.4	67.1	100.0	100.0

\* RMS CAL IS THE DISPLAYED VALUE FOR AVERAGE RESPONDING METERS THAT ARE CALIBRATED RMS FOR SINE WAVES.



## REFRIGERATION THEORY

Thermocouples are widely used in the process control and refrigeration industry. A review of basic refrigeration theory will help you to apply the meter in refrigeration applications.

In any refrigeration application the goal is to transfer heat from one place to another. The transfer is made by pumping a refrigerant from one area to another area whose temperature is different.

The refrigerant has a low boiling point and a high latent heat of vaporization. That is, a great deal of heat is required to convert the refrigerant from a liquid to a gas at its boiling temperature. The resulting gas is at the same temperature, but it contains more heat energy than the liquid did.

At atmospheric pressure, common refrigerant gasses such as Freon and Ammonia boil far below water freezing point, and absorb heat from their surroundings in the process. Likewise, as gasses condense, they release heat back into their environment.

We can control the boiling point by raising or lowering the pressure, forcing the gas to dissipate heat or absorb it. If we raise the pressure enough by compressing, it will become liquid. In a refrigeration system there is a compressor and a system of valves to change the pressure of a contained gas. The gas absorbs or dissipates heat in heat exchangers called evaporators or condensers, depending on how they are used. Figure 25 shows the basic parts of a refrigerator.

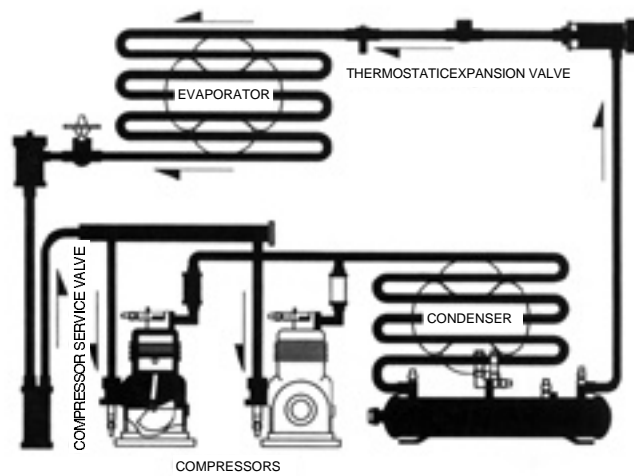

FigurE 25. Refrigeration System.

□ The Refrigeration Cycle

Inside a refrigerator, a compressed gas in liquid form is released through an expansion valve into the low pressure of an evaporator. Here the liquefied gas evaporates (boils). The expansion valve controls how much refrigerant boils, and thus, how much heat it absorbs. The refrigerant, now in gas form, circulates through the cooling coils carrying the heat away with

Once outside, the gas enters the compressor on the low-pressure side and is compressed. As it is compressed, the gas temperature rises above the surrounding air temperature. The hot gas dissipates its heat in the condenser, becoming liquid once again, before returning to the expansion valve.

In large systems the temperature and pressure are closely monitored to ensure long life and minimum energy usage. In small systems, like a home refrigerator, temperature is often measured as a troubleshooting aid. Careful temperature measurement at different points in the system can pinpoint trouble spots. Some of critical temperatures are discussed below.

#### **Important Temperature Measurements**

##### **Evaporator Temperature**

The entire mid-section of the evaporator is at the refrigerant's boiling temperature, which is related directly to the evaporator pressure. The evaporator temperature should be lower than the desired cooling temperature.

##### **Evaporator Superheat**

By the time the refrigerant reaches the last few turns of the evaporator coils, all the refrigerant should have become gas with a temperature slightly warmer than the evaporating temperature. The amount that the gas temperature exceeds its boiling point is called superheat. Superheat is a sensitive indicator of evaporator efficiency. The superheat gas temperature is usually taken at the expansion valve's sensing bulb. A proper superheat reading, ensures that all liquid has boiled.

### **Condenser Temperature**

The condenser's entire mid-section should be at the refrigerant's condensing temperature. The condensing temperature is related directly to the condenser's pressure, which is produced by the compressor's head-pressure.

The condenser temperature varies with the system's load, but it is designed to operate within certain limits. Load factors include the amount of heat absorbed by the evaporator, air temperature surrounding the condenser (ambient air temperature), and airflow over the condenser.

### **Temperature Difference (TD)**

The difference between ambient air and condensing temperature is a critical factor. The greater the temperature difference between hot refrigerant and air, the faster the heat will dissipate. If TD is too low, the refrigerant will not completely condense.

### **Condenser Superheat**

The temperature of the hot gas discharged from the compressor is higher than the condensing temperature. In the evaporator, the difference between the gas temperature and condensing temperature is called superheat. However, since the pressure here is far higher than at the evaporator, so is the temperature. Condenser superheat is usually measured as the difference between the first few condenser coils and the midsection. Abnormal superheat can indicate troubles such as condenser overload, lack of refrigerant, and presence of non-condensable gas.

### Condenser Sub-cool

Like the evaporator, the condenser is sized so that all the gas will be condensed before the last few coils, the liquid temperature drops slightly below the condensing temperature. In the case of an overloaded condenser or one short of refrigerant, there will be little or no subcooling.

Indication	Ambient air temperature (T2)		Condensing Temperature (T1)	TD T	Vapor In	Super Heat	Liquid Out	Sub-cool
Efficient Condenser	95°F 35°C	125°F 52°C	30°F 17°C	170°F 77°C	170°F 77°C	45°F 7°C	115°F 46°C	10°F -12°C
Low Refrigerant	95°F 35°C	102°F 39°C	7°F 4°C	190°F 88°	190°F 88°C	88°F 31°C	100°F 38°C	2°F -17°C
Inefficient Compressor	95°F 35°C	105°F 41°C	10°F 6°C	120°F 49°C	120°F 49°C	15°F -9°C	95°F 35°C	10°F -12°C
Overloaded Condenser	90°F 32°C	150°F 66°C	60°F 34°C	225°F 107°C	225°F 107°C	75°F 24°C	145°F 63°C	5°F -15°C
Non-Condensable Gas	95°F 35°C	130°F 54°C	35°F 19°C	225°F 107°C	225°F 107°C	95°F 35°C	120°F 49°C	10°F -12°C
This is an example of temperature indications for normal operation and various malfunctions for typical air conditioning unit.								

## MAINTENANCE

### WARNING

To avoid electrical shock, do not perform any servicing unless you are qualified to do so.

#### SERVICE

If the instrument fails to operate, check battery, test leads, etc. and replace as necessary. If the instrument still does not operate, double check operating procedure as described in this instruction manual. When servicing, use only specified replacement parts.

### WARNING

To avoid electrical shock or damage to the meter, do not get water inside the case. Remove the test leads and any input signals before opening the case.

#### 0 BATTERYREPLACEMENT

The meter is powered by a single 9V battery, with NEDA1604, S006P, IEC6F22 carbon-zinc alkaline, or similar battery. Replace battery if the low battery sign (-) is displayed and flashing. Use the following procedure

to replace the battery:

1. Remove the meter from the circuit and turn the rotary switch to the OFF position.
2. Disconnect the test leads from the instrument.
3. Loosen the screw on the battery cover.
4. Pull the cover up slightly and slide the battery cover off (see **Figure 26** and **Figure 27**).
5. Replace the defective battery.
6. Reverse the procedure of opening cover to close the battery cover.

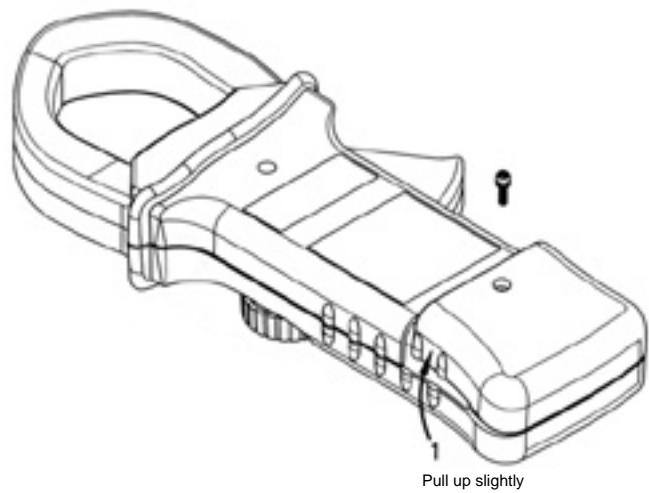

Figure 26. step 1 of Battery replacement.

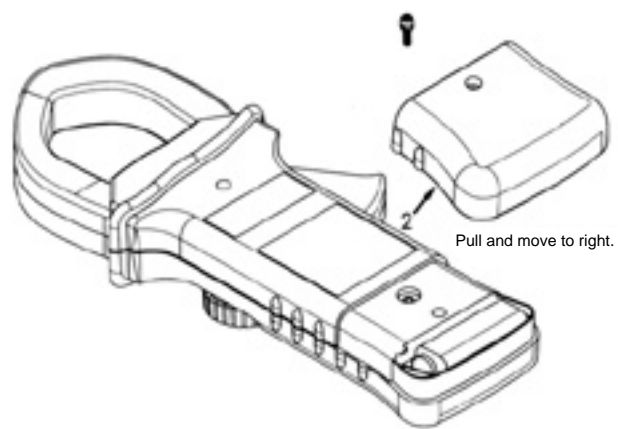

Figure 27. Step 2 of Battery Replacement.



**CLEANING**

To clean the instrument, use a soft cloth dampened in a solution of mild detergent and water. Do not spray cleaner directly onto the instrument, since it may leak into the cabinet and cause damage. Do not use chemicals containing benzene, toluene, xylene, acetone or similar solvents.